

BMM WESTON

Sterilizers

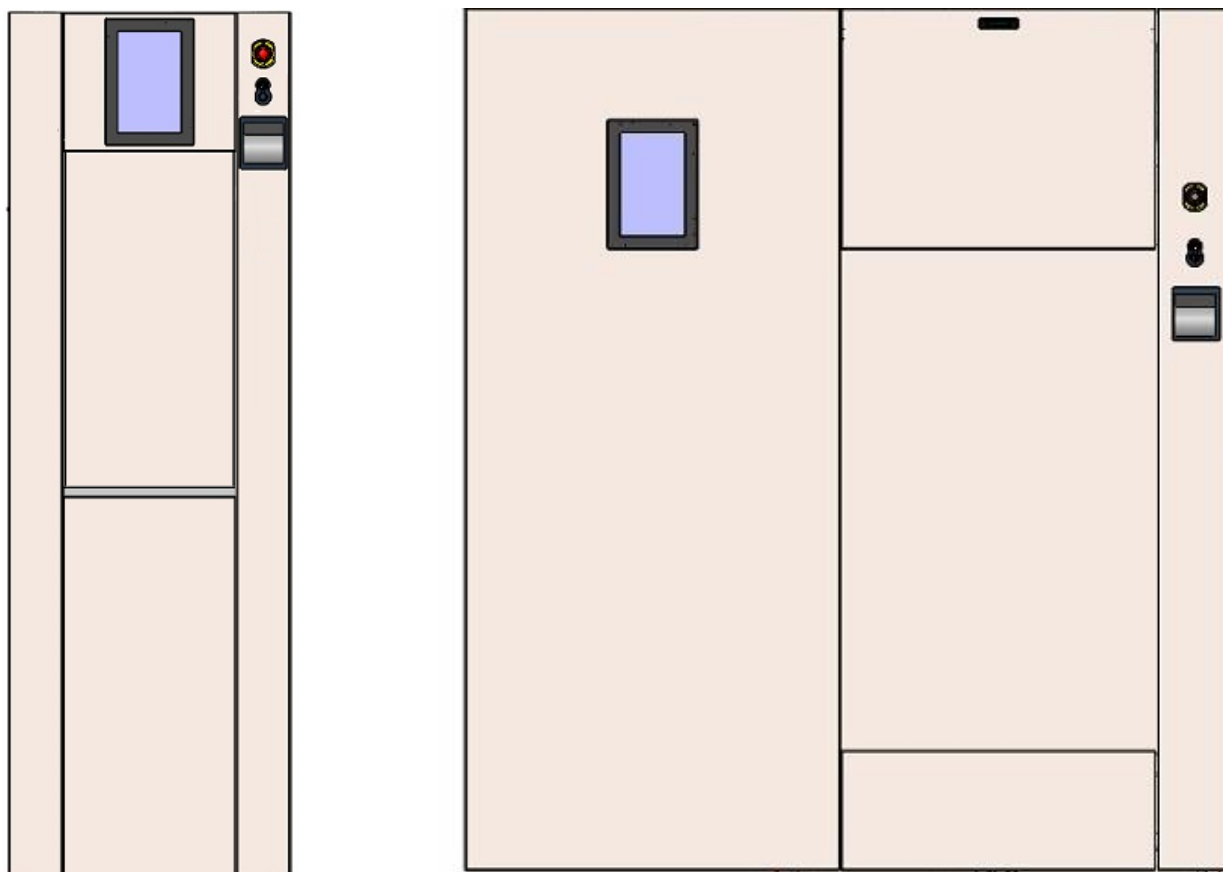

USER MANUAL LABORATORY STERILIZERS Series 1/2/3

AB3070 Rev. 2 20/04/23
Original Instructions

BMM WESTON LTD, WESTON WORKS, FAVERSHAM, KENT, ENGLAND

Head Office: Phone 01795 533441 Fax 01795 538891 Email: mail@bmmweston.com Website: www.bmmweston.com
Service Dept: Phone 01795 597127 Fax 01795 538891 Email: service@bmmweston.co.uk

CONTENTS

Contents

Preface	4
Intended Use and Sterilization Cycles	5
Safety Instructions	7
Safety Nomenclature	7
Operating the Sterilizer	7
Loading and Unloading the Sterilizer	8
Processed Items and Cycles.....	8
Door Operation	8
End of Cycle.....	8
Environmental Considerations	8
Maintenance and Management.....	9
Disposal Instructions	9
Operator Controls	10
Touchscreen keypad	11
Daily Maintenance	13
Door Seal.....	13
Cleaning.....	13
Daily Tests.....	13
Loading Equipment.....	14
Carriage Loading	15
Loading Shelves	16
Operation and Resetting Emergency Stop Button	17
Starting a Cycle	18
Ending a Cycle	23
Auxiliary Menus:	24
Supervisor Menu – Cycle Dependent Options:.....	25
Supervisor Menus – Copying Profiles From Cycle to Cycle:	26
Supervisor Menu - Menu Entry Logs:	27
Supervisor Menu - Change I.D.s and Passcodes:.....	28
Cycle Log Store Menu:	28
Integral Boiler Control.....	30
Printer.....	31
Spare Parts	32

Preface

THIS MANUAL CONTAINS IMPORTANT INFORMATION FOR THE OPERATOR AND SUPERVISOR IN THE OPERATION AND DAILY MAINTENANCE OF THE STERILIZER.

WARNING - ALL OPERATORS OF THE STERILIZER SHOULD BE GIVEN APPROPRIATE TRAINING IN THE USE OF THE STERILIZER. THE OPERATOR SHOULD BE AWARE OF THE TYPE OF LOADS THE STERILIZER IS DESIGNED TO PROCESS AND THOSE THAT SHOULD NOT BE PROCESSED. ALL OPERATORS SHOULD BECOME ACQUAINTED WITH THE SECTION ENTITLED SAFETY INSTRUCTIONS CONTAINED WITHIN THIS MANUAL.



Warning Symbol – Black exclamation mark symbol on a yellow background contained within a black triangular band. This symbol is included on the sterilizer label indicating that accompanying documents must be consulted before operating the sterilizer in order to find out the nature of the potential hazards and any actions which have to be taken to avoid them. Particular attention should be paid to the safety instructions section and the caution and warning statements contained throughout the manual.

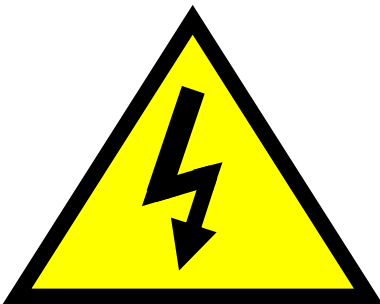

Electric Flash Hazard Symbol – Black flash symbol on a yellow background contained within a black triangular band. Sign attached to the covers and lids of all electrical enclosures, junction boxes and operator control panel. Indicates a warning to personnel that an electrical hazard will be present on the removal of the cover, lid or panel. Only qualified maintenance and test engineers should be allowed to remove these covers, lids and panels.

Intended Use and Sterilization Cycles

WARNING – READ THE FOLLOWING INSTRUCTIONS CAREFULLY BEFORE ANY ATTEMPT IS MADE AT OPERATING THE STERILIZER OR FIRST PLACING THE STERILIZER INTO USE.

WARNING – All Operators of the sterilizer should be given appropriate training in use of the sterilizer. If coded access to the sterilizer is used, each operator should be given a code to access only those functions and operations they are required to use.

The cycles fitted to the sterilizer will include some, if not all, of the following:

(a) Porous Material Cycles

Uses high-temperature steam to process porous items such as linen, towels and cotton coats. Also used to sterilize items such as animal bedding, foodstuff and cages. Disinfection is by means of direct contact with steam at a preferred temperature of 134°C, for a minimum of 3 minutes.

As air is trapped in porous loads, an efficient and reliable air removal system is essential prior to the disinfection stage. This type of process should not be used for heat-sensitive materials.

(b) Plastic Discard Cycles

Use high-temperature steam and designed to make safe plastic discard material where no one item contains more than 50 ml of aqueous fluid i.e. culture media contained within plastic petri dishes. The material to be sterilized would normally be contained within a stainless steel discard box. Sterilization is by means of heating with steam at a preferred temperature of 134°C, for a minimum of 3 minutes.

As air is normally trapped within and around the load items, an efficient and reliable air removal system is essential prior to the sterilization stage.

A cooling stage is fitted and the control system set so that the load cannot be released from the chamber until it has fallen to below 90°C.

(c) Fluid Discard Cycles

Use high-temperature steam and designed to make safe fluid discard material in glass containers and large plastic containers exceeding 50 ml. Sterilization is by means of heating with steam at a preferred temperature of 121°C or 126°C, for a minimum time of 15 or 10 minutes respectively.

A cooling stage is fitted and the control system set so that the load cannot be released from the chamber until it has fallen to below 80°C.

(d) Fluid Cycles

Use high-temperature steam and designed to sterilize fluid in glass and large plastic containers exceeding 50 ml. Sterilization is by means of heating with steam at a preferred temperature of 121°C, for a minimum time of 15 minutes. A cooling stage is fitted and the control system set so that the load cannot be released from the chamber until it has fallen to below 80°C.

(e) Glassware and Equipment Cycles

Use high-temperature steam and designed to sterilize empty glassware without caps and other non-porous equipment. Sterilization is by means of direct contact with steam at a preferred temperature of 134°C, for a minimum time of 3 minutes. Where caps are fitted, preventing the removal of air, the glassware should be considered as disinfected but not sterilized.

(f) Free Steaming Cycles

Use low-temperature steam and designed to heat culture media solutions contained within vented glass or plastic containers. Heating is by means of steam at a preferred temperature of 100°C.

NOTE - FOR ADDITIONAL INFORMATION ON PROCESS AND TEST CYCLES REFER TO THE DEPARTMENT OF HEALTH PUBLICATION – CFPP 01-01 Parts B and C.

CFPP part 3 also provides a list that details the frequency the test cycles should be carried out:

Daily test – User

Bowie-Dick test for steam penetration

Weekly tests – CP(D)

1. Weekly safety checks
2. Air leakage test
3. Air detector function test
4. Automatic control test
5. Bowie-Dick test for steam penetration

For details of the parameters and tolerances critical to the sterilization process refer to the commissioning report or most recent re-validation report. These reports will also provide a record of the pressure/temperature profiles against time for the standard loads and cycles tested at that time.

Safety Instructions

It is the responsibility of the User to ensure that all personnel who come into contact with the sterilizer fully understand and comply with the safety instructions contained within this manual. This applies equally to all personnel engaged in the operation, maintenance and testing of the sterilizer.

Safety Nomenclature

Instructions may be in the form of NOTES, CAUTIONS, and WARNINGS, and are used in the manual to draw attention to important work and safety practices.

NOTE – A NOTE IS USED TO DRAW ATTENTION TO AN INSTRUCTION THAT IS NOT DIRECTLY RELATED TO PERSONNEL SAFETY OR DAMAGE TO THE MACHINE.

CAUTION - A CAUTION IS USED TO INDICATE A HAZARDOUS SITUATION THAT MAY RESULT IN INJURY TO PERSONNEL OR DAMAGE TO THE MACHINE.

WARNING - A WARNING IS USED TO INDICATE A HAZARDOUS SITUATION WHICH HAS SOME PROBABILITY OF LEADING TO DEATH OR SERIOUS PERSONAL INJURY.

WARNING – READ THE FOLLOWING INSTRUCTIONS CAREFULLY BEFORE ANY ATTEMPT IS MADE WHEN OPERATING THE STERILIZER FOR THE FIRST TIME OR WHEN FIRST PLACING THE STERILIZER INTO USE.

The following instructions should be carried out in order that the sterilizer is operated safely, and that maintenance and validation tasks are undertaken at regular intervals to ensure that the sterilizer continues to function safely and product continues to be processed satisfactorily.

Operating the Sterilizer

WARNING – All Operators should be given appropriate training in use of the sterilizer. If coded access to the sterilizer is used, each operator should be given a code to access only those functions and operations they are authorized to use. Training should be ongoing and reviewed regularly. Training records should be documented.

WARNING – If the equipment is used in a manner not specified in this manual, the protection provided by the equipment may be impaired.

CAUTION - Do not touch any part of the sterilizer chamber or door. These parts are likely to be hot and could cause burns if touched without wearing heat protective clothing and gloves.

WARNING – Do not enter or partially enter the sterilizer chamber without first obtaining the key for the control panel auto/manual door switch and then turning the switch to the manual position. With the switch in the manual position, remove the key and keep on your person until it is safe to return the switch to the auto position and for normal operation of the sterilizer to resume.

CAUTION – All sterilizer keys should be held in safe and secured storage. The issuing of keys should be authorised by the person/s responsible for their safe storage.

CAUTION – After use, no key should be left in any key switch. The key should be returned to the person/s responsible for the safe storage of the sterilizer keys.

WARNING – An electrical power disconnection device (isolator) is sited in the plantroom area. This should be turned off and locked if work of a hazardous nature is to be performed on the sterilizer. Equipment should not be positioned in such a way that it is difficult to access this device.

Loading and Unloading the Sterilizer

CAUTION - Always wear heat protective gloves when handling, removing, or partially removing load carriers or shelves from the sterilizer chamber. Load carriers, shelves and load items are likely to be hot and could cause burns if touched without wearing heat protective gloves.

CAUTION – When transferring a load carrier from the sterilizer chamber onto a trolley, or from the trolley into the chamber, always ensure that the trolley locking device is engaged to the sterilizer chamber locking plate.

CAUTION – Do not overload loading carriage. This may give rise to excessive effort being required to maneuver the trolley and in transferring the loading carriage on and off the trolley.

Processed Items and Cycles

CAUTION – Articles to be sterilized should be presented to the sterilizer in a clean state in order to reduce bioburden levels. For guidance on bioburden, refer to EU standards BS EN 17665 and EN556.

CAUTION – Heat sensitive items unable to withstand the sterilizing temperatures of cycles fitted to the sterilizer, should not be processed in the sterilizer. If in any doubt as to the suitability of the sterilizing cycle, seek advice from the person responsible for the sterilizer. Advice from the manufacturer of the item to be sterilized may need to be obtained.

CAUTION – Fluids, in sealed or unsealed containers, must not be processed in sterilizers and sterilizing cycles designed solely for processing medical devices. Hot fluids can cause an explosion hazard.

Door Operation

CAUTION – When the Sterilizer door is closing keep clear to avoid entrapment.

CAUTION – Before closing the sterilizer door ensure that no load carrier, shelf or load item protrudes from the chamber. Failure to do so may result in damage to the protruding article.

CAUTION – When opening or closing the sterilizer door, ensure that the loading trolley or shelf is clear of the moving door. Failure to do so may result in damage to the sterilizer panelwork.

Caution – Do not allow articles to be sterilised to overhang the sides of a load carrier or shelving system. Articles or their packaging may be damaged when they are being transferred into or out of the sterilizer, and this may affect their sterile condition after removal from the sterilizer.

End of Cycle

WARNING – Always check the printed sterilizer cycle log at cycle end to confirm whether the cycle was a pass cycle and that the cycle was appropriate for the sterilization of the processed goods.

WARNING - Never release goods for use from a failed cycle – all goods should be reprocessed to achieve sterilization.

WARNING – If a fault condition message appears on the operator message screen, report fault condition to person/s responsible for the sterilizer so that appropriate action can be taken in determining the reason/s for the fault.

Environmental Considerations

CAUTION – This sterilizer has been tested and conforms to the requirements of EN 61000 standard on Electromagnetic Compatibility. If the sterilizer is sited in an area where the limits of electromagnetic radiation, applied by this standard, are likely to be exceeded, i.e. close to X-ray or magnetic resonance imaging equipment, advice should be obtained from the manufacturers of both the sterilizer and the high electromagnetic source equipment.

CAUTION – Peripheral equipment connected to the sterilizer external ports i.e. data collection computers, must conform to BS EN 60950 – Specification for safety of information technology equipment, including electrical business equipment.

CAUTION – The Sterilizer should be operated in a local environment where the temperature does not exceed 40°C and a relative humidity not exceeding 80%.

CAUTION – For the Operator screens to be read and operated correctly, the screen should not be subject to direct sunlight or other bright light sources.

CAUTION – Adequate lighting should be provided in the plantroom and the operator work area to enable indicators and gauges to be readable (by normal or corrected vision) from a distance of 1 m at any external illumination level in the range of (215 ± 15) lx to (1 500 ± 15) lx.

Maintenance and Management

WARNING – Before any attempt is made to work on the sterilizer, ensure that all services to the machine are isolated and where appropriate locked, and that any pressure retaining parts are safely reduced to atmospheric pressure.

WARNING – The installation of the sterilizer should only be undertaken by suitably trained and skilled personnel. The installation procedures and checks should be documented to demonstrate that the installation is safe to use and has been installed to specification.

WARNING – A scheme of inspection for the safety of the sterilizer pressure vessel and door should be instituted. A Competent Person for the inspection of pressure vessels should be appointed.

WARNING – After installation, the sterilizer should be commissioned and validated to demonstrate that the sterilizer, as installed, is safe to use and operates to specification. This is a documented procedure, and should be undertaken by suitably qualified personnel.

WARNING – In use, the sterilizer should be periodically maintained and tested to ensure that the sterilizer continues to function safely and that its performance continues to be within specification. This is a documented procedure, and should be undertaken by suitably qualified personnel.

WARNING – The safe state of the equipment must be verified after any repair.

NOTE – For the management of Sterilizers see the requirements detailed in Department of Health guidance note Choice Framework for local Policy and Procedures 01-01, Parts A, B and C.

Disposal Instructions

According to the WEEE Directive 2002/96/EC, all categories of electrical and electronic equipment (EEE) covered by this directive in the ANNEX IA should be disposed of and collected separately and use the best available treatment, recovery and recycling techniques.

EEE contains hazardous substances to the human health and environment but EEE is also a valuable resource of raw materials. Therefore it is important to collect WEEE separately from other wastes.

BMM Weston sterilizers are subject to the Directive and we therefore urge you to dispose of the equipment separately from 'normal' household waste and make sure that it is properly treated, recovered or recycled to protect human health and the environment.

Sterilizer packaging (wooden crates, plastic wrapping etc.) should be disposed of in the same manner as conventional waste of the same material.



Applies to Electrical Control system fitted to Sterilizer

The symbol shown here means that the product is classed as Electrical or Electronic Equipment and should not be disposed with other household or commercial waste at the end of its working life.

The Waste of Electrical and Electronic Equipment (WEEE) Directive (2002/96/EC) has been put in place to recycle products using best available recovery and recycling techniques to minimize the impact on the environment, treat any hazardous substances and avoid increasing landfills.

Contact your local authority or the nearest collection site to dispose of Electrical and Electronic Equipment waste.

For disposal of entire sterilizer (end-of-life) contact BMM Weston for recommendations.

Operator Controls

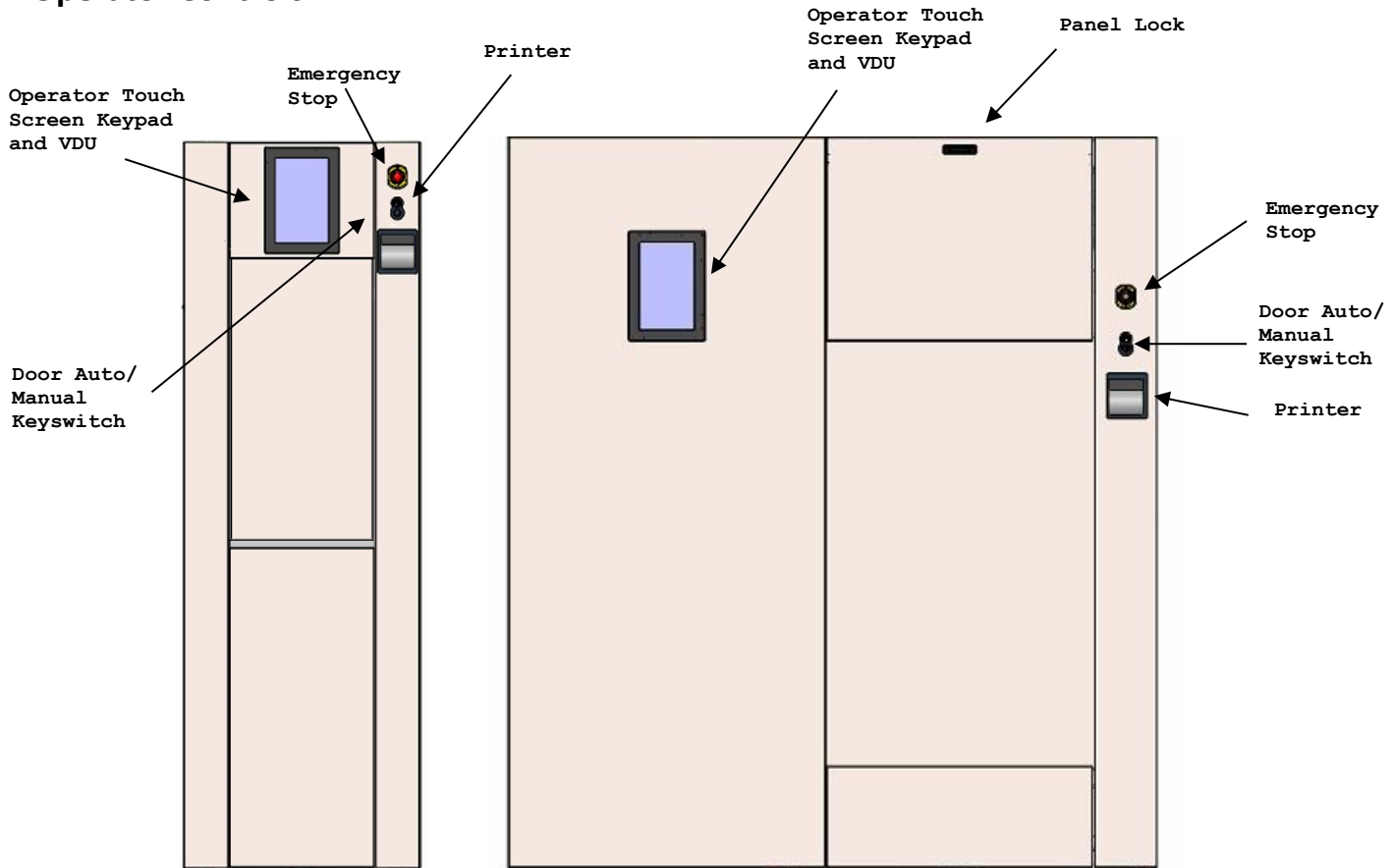

PANEL LOCK

Fold away pull lever allowing access to door switches, door speed controllers etc.

WARNING –

THE PULL DOWN PANEL SHOULD ONLY BE REMOVED BY SUITABLY QUALIFIED MAINTENANCE PERSONNEL. REMOVAL OF THE PANEL EXPOSES PERSONNEL TO MOVING PARTS AND CRUSHING HAZARDS.

OPERATOR VDU

The Operator Touchscreen and VDU (visual display unit) are used for cycle selection, data input, sterilizer configuration, and maintenance tasks. In addition the screen can display menus for Supervisor, Validation and Maintenance requirements as well as door and boiler control.

PRINTER

The printer is situated below the door auto/manual keyswitch and emergency stop button. The printer provides a record of process variables, stages and times throughout the sterilizing cycle – the cycle log. In addition to the cycle log, the contents of the Supervisor, Validation and Configuration menus can be printed for archive purposes.

EMERGENCY STOP

Operation of the emergency stop switch will remove electrical power from all electric motors and control solenoid valves. If the door or sealing system is operating, this will be immediately halted. No door operations are possible until the emergency stop system has been reset. *Warning – see section on the Operation and Resetting of the Emergency Stop Button.*

DOOR AUTO/MANUAL KEYSWITCH

Allows for the door to be switched from automatic to manual control and vice-versa.

OPERATOR CONTROLS

Touchscreen keypad

The Operator touch sensitive screen is used for inputting data and control of the sterilizer.

Alphanumeric Keypad for data entry:

										X	
1	2	3	4	5	6	7	8	9	0		
Q	W	E	R	T	Y	U	I	O	P	←	
	A	S	D	F	G	H	J	K	L	↵	
↓	Z	X	C	V	B	N	M	:	;	↑	
&123									←	→	

Back Space Key

Enter Key

Arrow Keys for Movement of Cursor

On pressing the '&123' key the following keypad will be displayed:

										X	
1	2	3	4	5	6	7	8	9	0	←	
_	/	:	;	()	€	&	@		↵	
#+=		.	,	?	!	'	"			#+=	
ABC									←	→	

Back Space Key

Enter Key

Arrow Keys for Movement of Cursor

On pressing either of the '#+=' keys the following keypad will be displayed:

										X	
1	2	3	4	5	6	7	8	9	0	←	
[]	{	}	#	%	^	*	+	=		
-	\		~	<	>	\$	£	¥		↵	
123		.	,	?	!	'	"			123	
ABC									←	→	

Back Space Key

Enter Key

Arrow Keys for Movement of Cursor

OPERATOR CONTROLS

Numeric Keypad for data entry:

On selecting a field, the current value will be displayed for that field.

			X
min	9		max
1			31
7	8	9	←
4	5	6	±
1	2	3	↵
0		.	

Back Space Key

Addition of +/- symbol (where appropriate)

Enter Key

min – the minimum value that can be entered

max – the maximum value that can be entered

When the new value has been set, pressing the Enter Key will update the field.

Daily Maintenance

These tasks should be carried out by the user/operator.

CAUTION – BEFORE CARRYING OUT ANY OF THE TASKS DETAILED BELOW, READ THOROUGHLY THE GENERAL SAFETY INSTRUCTION CONTAINED WITHIN THIS MANUAL.

Door Seal

Clean the surface of the door seal with a damp cloth, wetted with water, to remove any deposits.

Visually inspect the condition of the door seal checking for any cuts or damage that might affect its ability to seal when the door is in a sealed state. If any doubt exists as to the condition of the door seal, report this to the person responsible for the sterilizer.

CAUTION – WHEN CLEANING OR INSPECTING THE DOOR SEAL, ALWAYS WEAR HEAT PROTECTIVE GLOVES. DOOR AND CHAMBER PARTS ARE LIKELY TO BE VERY HOT.

Cleaning

The stainless steel facia panel can be cleaned with a damp cloth, wetted with water or disinfectant. A liquid stainless steel polish can be used but check that its use does not present any microbial problems.

Clean the operator VDU and printer cover with a damp cloth, wetted with water. Do not use any solvent cleaners on these surfaces.

WARNING – DO NOT ENTER OR PARTIALLY ENTER THE STERILIZER CHAMBER WITHOUT FIRST OBTAINING THE KEY FOR THE CONTROL PANEL AUTO/MANUAL DOOR SWITCH AND THEN TURNING THE SWITCH TO THE MANUAL POSITION. WITH THE SWITCH IN THE MANUAL POSITION, REMOVE THE KEY AND KEEP ON YOUR PERSON UNTIL IT IS SAFE TO RETURN THE SWITCH TO THE AUTO POSITION AND FOR NORMAL OPERATION OF THE STERILIZER TO RESUME.

CAUTION – ALL STERILIZERS KEYS SHOULD BE HELD IN SAFE AND SECURED STORAGE. THE ISSUING OF KEYS SHOULD BE AUTHORISED BY THE PERSON/S WHO IS/ARE RESPONSIBLE FOR THE SAFE STORAGE OF THE STERILIZER KEYS.

CAUTION – WHEN REMOVING THE CHAMBER FILTERS AND/OR CLEANING THE CHAMBER, ALWAYS WEAR HEAT PROTECTIVE GLOVES AND CLOTHING. CHAMBER PARTS ARE LIKELY TO BE VERY HOT AND TO CAUSE BURNS.

Instrumentation

Check the VDU to establish that all the services are turned on and that the correct readings are indicated on the VDU.

Daily Tests

A Bowie and Dick Cycle should be run daily, preferably at the beginning of the day. The chemical indicator will demonstrate the effectiveness of the air removal process. If an even colour change is not obtained across the indicator paper, do not use the sterilizer until the cause is fixed.

A Leak Rate Test should be run on a weekly, if not daily basis, to check the integrity of the chamber/door system and associated pipework. The test is designed to check the air tightness of the system and to fail the cycle if air leakage is above a pre-defined value. If the Leak Rate Test indicates a failure, inform the person responsible for the sterilizer.

WARNING - IF ANY OF THE REQUIREMENTS FOR THAT TEST ARE NOT MET, DO NOT USE THE STERILIZER. REPORT THE FAILURE TO THE PERSON RESPONSIBLE FOR THE STERILIZER. THE STERILIZER SHOULD ONLY BE USED AFTER THE CAUSE OF THE FAILURE HAS BEEN ESTABLISHED AND CORRECTIVE ACTION HAS BEEN TAKEN.

Check the log book and production records. Complete as required.

Printer

Check that the printer is loaded with sufficient paper for the day's operation.

Loading Equipment

The general arrangement of the sterilizer loading equipment is shown in the diagram below.

The equipment comprises a loading trolley upon which sits the loading carriage. The loading carriage is fitted with wheels and is guided onto and off of the trolley by means of rails fitted to the trolley.

A similar set of rails is fitted to the floor of the chamber, and when the trolley and chamber rails are aligned, the loading carriage can be transferred into or out of the chamber.

With the carriage pulled onto the trolley and the carriage wheel contacting the carriage stop, the locking lever in the locked position will raise the carriage locking bar to secure the carriage to the trolley. In this position the trolley and carriage can be wheeled safely around the work area.

CAUTION – ALWAYS ENSURE THAT THE CARRIAGE LOCKING BAR IS IN THE RAISED POSITION, SECURING THE CARRIAGE TO THE TROLLEY BEFORE MOVING THE TROLLEY AND CARRIAGE AROUND THE WORK AREA.

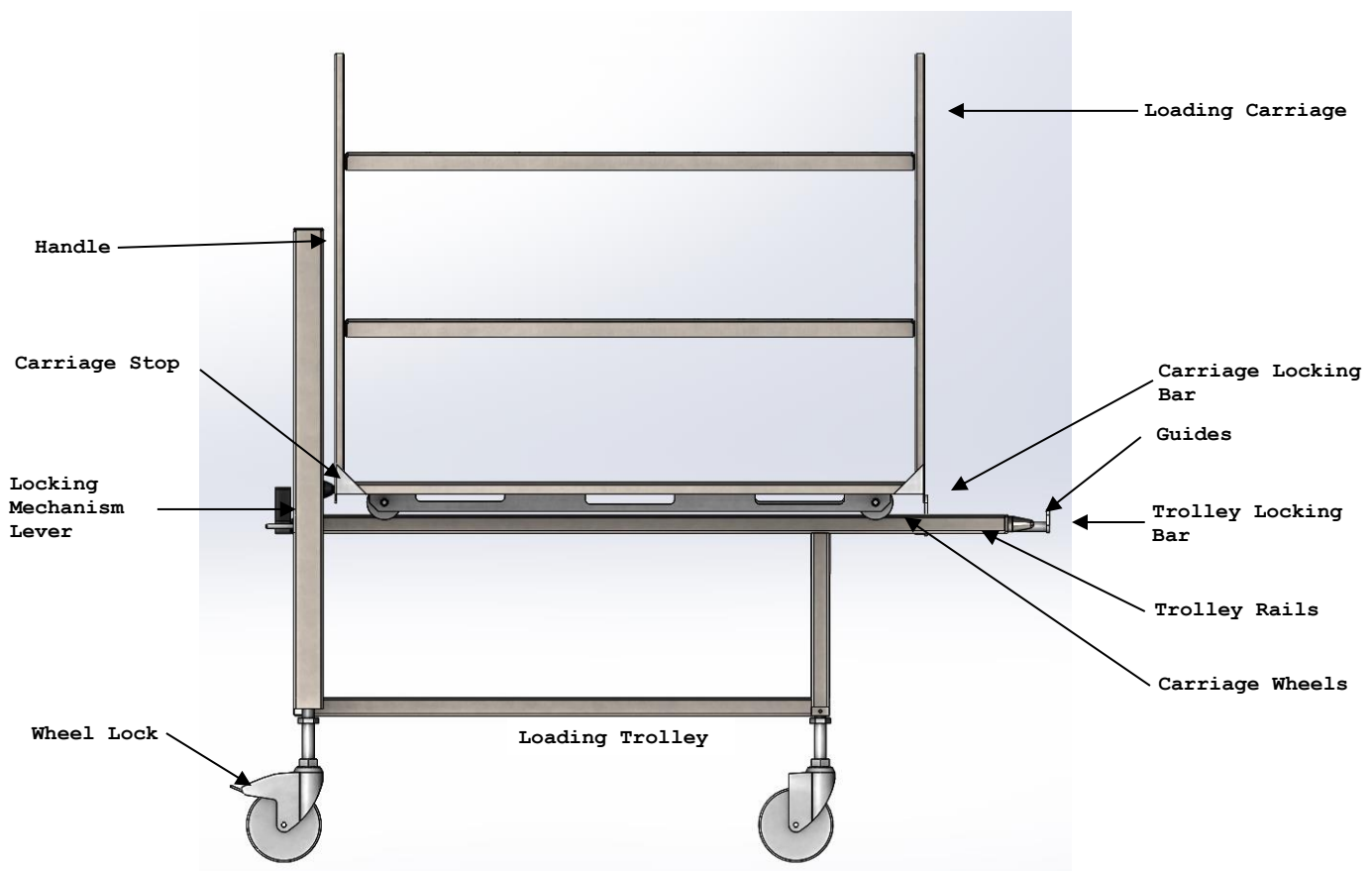

With the sterilizer door in the open position, the loaded carriage and trolley is pushed up to the chamber. The trolley should be steered to align with the chamber. As the trolley approaches the chamber, the guides fitted to the front of the trolley rails will begin to engage the chamber rails to align the two sets of rails. When the two sets of rails are abutted, the trolley locking lever is turned to the unlock position. This will cause the carriage locking bar to be lowered whilst at the same time, the trolley locking bar to engage the chamber locking plate within the chamber. The engagement of the trolley locking bar to the chamber locking plate will prevent the trolley moving whilst the carriage is either transferred into or out of the sterilizer. For additional security, the trolley wheel locks should be operated, by pushing the wheel locking bars downward.

CAUTION – WHEN TRANSFERRING THE LOADING CARRIAGE INTO OR OUT OF THE CHAMBER, ENSURE THAT THE TROLLEY LOCKING BAR IS SECURELY ENGAGED TO THE CHAMBER LOCKING PLATE SO THAT THE TROLLEY IS HELD IN POSITION. ALSO ENSURE THAT THE TROLLEY WHEEL LOCKS ARE OPERATED TO PREVENT MOVEMENT OF THE TROLLEY DURING THE LOADING OR UNLOADING OPERATION.

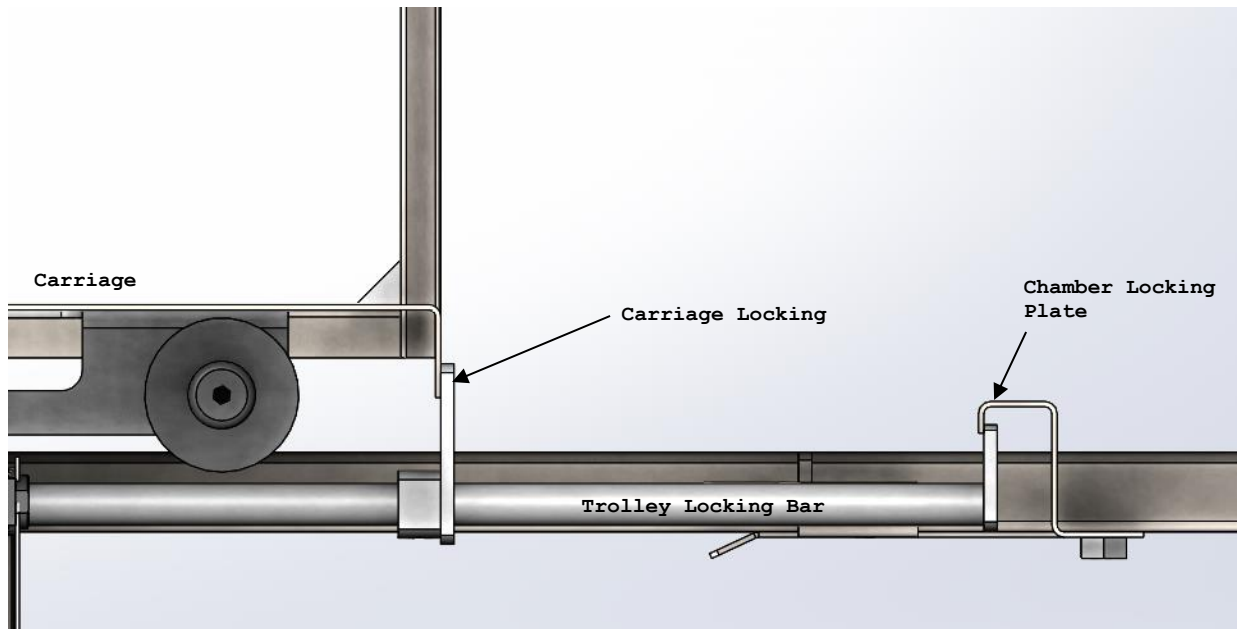

When the carriage has been pushed fully into the chamber, the trolley locking lever is turned to the carriage lock position to release the trolley locking bar from the chamber locking plate. The trolley wheel locks can be released by raising the locking bars and the trolley can then be wheeled clear of the sterilizer.

CAUTION – BEFORE CLOSING THE STERILIZER DOOR ENSURE THAT THE CARRIAGE DOES NOT PROTRUDE FROM THE STERILIZER CHAMBER.

CAUTION – WHEN OPENING OR CLOSING THE STERILIZER DOOR, ENSURE THAT THE LOADING TROLLEY IS CLEAR OF THE DOOR. FAILURE TO DO SO MAY RESULT IN DAMAGE TO THE STERILIZER PANELWORK.

To unload the carriage from the chamber, the sequence of events as described above should be followed. When unloading the carriage from the sterilizer, or handling recently sterilized load items, always wear heat protective gloves.

CAUTION - ALWAYS WEAR HEAT PROTECTIVE GLOVES WHEN HANDLING/REMOVING LOAD CARRIERS OR SHELVES FROM THE STERILIZER CHAMBER. LOAD CARRIERS, SHELVES AND LOAD ITEMS ARE LIKELY TO BE HOT AND COULD CAUSE BURNS IF TOUCHED WITHOUT WEARING HEAT PROTECTIVE GLOVES.

Carriage Loading

To ensure that the carriage shelves are not overloaded and that the load items are dry after a sterilization cycle, instrument trays should only be placed on the shelves in single layers. The loaded items should not overhang the sides of the shelves or carriage.

CAUTION – DO NOT OVERLOAD CARRIAGE AND SHELVES.

CAUTION – DO NOT ALLOW ARTICLES TO BE STERILISED TO OVERHANG THE SIDES OF A LOAD CARRIER OR SHELVING SYSTEM. ARTICLES OR THEIR PACKAGING MAY BE DAMAGED WHEN THEY ARE BEING TRANSFERRED INTO OR OUT OF THE STERILIZER, AND THIS MAY AFFECT THEIR STERILE CONDITION AFTER REMOVAL FROM THE STERILIZER.

Loading Shelves

If loading shelves have been supplied with the sterilizer, they may be extended and retracted by gripping the handle and pushing or pulling as appropriate.

CAUTION – GLOVES SHOULD BE WORN WHEN LOADING OR UNLOADING THE SHELVES.

CAUTION – WHEN RETRACTING THE SHELVES ENSURE THAT THEY HAVE REACHED THE STOP POINT AT THE REAR OF THE CHAMBER SO THAT THEY DO NOT IMPEDE THE MOTION OF THE STERILIZER DOOR AS IT CLOSES.

CAUTION – SPREAD LOADS EVENLY ACROSS THE LENGTH AND WIDTH OF THE LOADING SHELF. OVERLOADING OR IMPROPER LOADING MAY CAUSE DAMAGE OR DEFORMATION TO THE SHELF OR HARM TO THE USER.



Shelves in closed position



Shelves in open position

EMERGENCY STOP BUTTON

Operation and Resetting Emergency Stop Button

When the Emergency Stop is operated, all electrical motors are isolated and all control valves become inhibited.

If the door is moving open or closed the valve will remain its position and therefore keep closing or opening.

The VDU will display

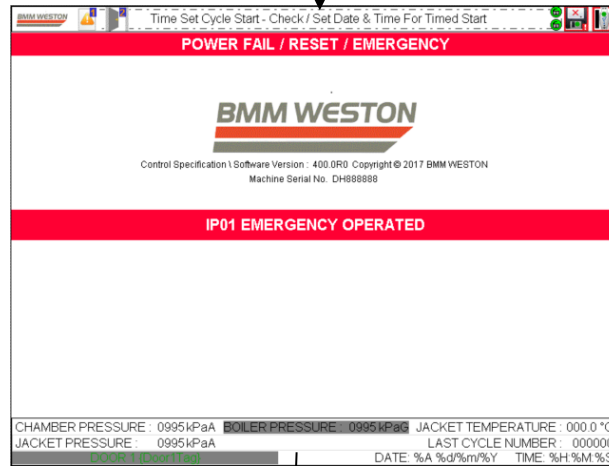

RESETTING EMERGENCY STOP

WARNING – MAKE SURE THAT THE REASON FOR OPERATING THE EMERGENCY STOP HAS BEEN REMOVED AND IT IS SAFE TO RETURN THE STERILIZER TO NORMAL OPERATION

In order to reset the emergency stop an authorised key holder must use the emergency stop key to release the emergency stop. This will return the machine to a safe state before returning to the menus.

VDU if the door is in the open or intermediate position

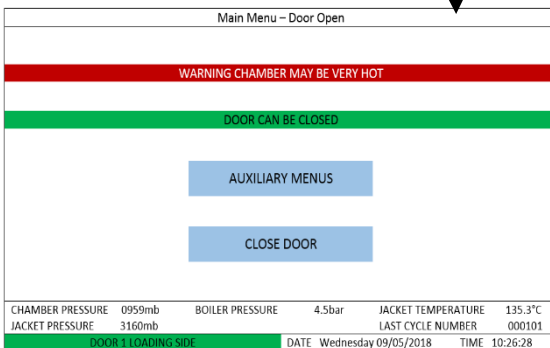

VDU if the door is in the closed position

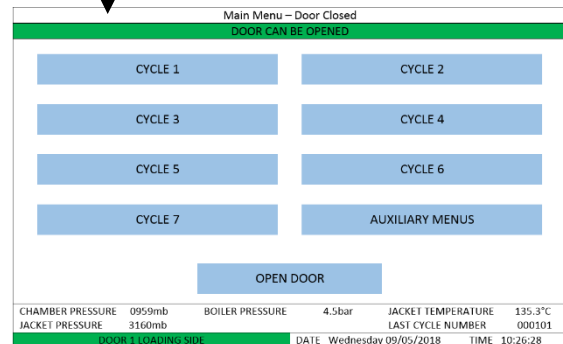

STARTING A CYCLE

Starting a Cycle

NOTE: IF THE STERILIZER HAS AN INTEGRAL BOILER REFER TO BOILER CONTROL SECTION (TO START THE BOILER BEFORE ATTEMPTING TO RUN A CYCLE)

BEFORE ANY ATTEMPT IS MADE TO LOAD THE STERILIZER OR START A CYCLE, THE SAFETY INSTRUCTIONS INCLUDED AT THE FRONT OF THIS MANUAL SHOULD BE READ CAREFULLY AND OBSERVED AT ALL TIMES.

If the door is in the closed position, press the OPEN DOOR button on the control cabinet. The door, when open, will display the main menu as below, with options to access auxiliary menus or close the door:

Main Menu – Door Open					
WARNING CHAMBER MAY BE VERY HOT					
DOOR CAN BE CLOSED					
<div style="background-color: #ADD8E6; padding: 5px; margin: 5px auto; width: 150px;">AUXILIARY MENU</div> <div style="background-color: #ADD8E6; padding: 5px; margin: 5px auto; width: 150px;">CLOSE DOOR</div>					
CHAMBER PRESSURE	0959mb	BOILER PRESSURE	4.5bar	JACKET TEMPERATURE	135.3°C
JACKET PRESSURE	3160mb			LAST CYCLE NUMBER	000101
DOOR 1 LOADING SIDE		DATE	Wednesday 09/05/2018	TIME	10:26:28

Transfer the load into the sterilizer, making sure that no part of the load touches the chamber walls. Read the safety instructions section at the front of this manual for the safe handling of loads in and out of the sterilizers.

Press and hold the close door button to close the door.

When the door is fully closed the cycle selection screen will be displayed as below.

Main Menu – Door Closed					
DOOR CAN BE OPENED					
<div style="background-color: #ADD8E6; padding: 5px; margin: 5px auto; width: 150px;">CYCLE 1</div>		<div style="background-color: #ADD8E6; padding: 5px; margin: 5px auto; width: 150px;">CYCLE 2</div>			
<div style="background-color: #ADD8E6; padding: 5px; margin: 5px auto; width: 150px;">CYCLE 3</div>		<div style="background-color: #ADD8E6; padding: 5px; margin: 5px auto; width: 150px;">CYCLE 4</div>			
<div style="background-color: #ADD8E6; padding: 5px; margin: 5px auto; width: 150px;">CYCLE 5</div>		<div style="background-color: #ADD8E6; padding: 5px; margin: 5px auto; width: 150px;">CYCLE 6</div>			
<div style="background-color: #ADD8E6; padding: 5px; margin: 5px auto; width: 150px;">CYCLE 7</div>		<div style="background-color: #ADD8E6; padding: 5px; margin: 5px auto; width: 150px;">AUXILIARY MENU</div>			
<div style="background-color: #ADD8E6; padding: 5px; margin: 5px auto; width: 200px;">OPEN DOOR</div>					
CHAMBER PRESSURE	0959mb	BOILER PRESSURE	4.5bar	JACKET TEMPERATURE	135.3°C
JACKET PRESSURE	3160mb			LAST CYCLE NUMBER	000101
DOOR 1 LOADING SIDE		DATE	Wednesday 09/05/2018	TIME	10:26:28

If sub-cycles are available the sub-cycle selection menu will be displayed on selecting a cycle:

Sub Menu – Door Closed					
DOOR CAN BE OPENED					
<div style="background-color: #ADD8E6; padding: 5px; margin: 5px auto; width: 150px;">CYCLE X</div>		<div style="background-color: #ADD8E6; padding: 5px; margin: 5px auto; width: 150px;">CYCLE X</div>			
<div style="background-color: #ADD8E6; padding: 5px; margin: 5px auto; width: 150px;">CYCLE X</div>		<div style="background-color: #ADD8E6; padding: 5px; margin: 5px auto; width: 150px;">CYCLE X</div>			
<div style="background-color: #ADD8E6; padding: 5px; margin: 5px auto; width: 150px;">CYCLE X</div>		<div style="background-color: #ADD8E6; padding: 5px; margin: 5px auto; width: 150px;">CYCLE X</div>			
<div style="background-color: #ADD8E6; padding: 5px; margin: 5px auto; width: 150px;">CYCLE X</div>		<div style="background-color: #ADD8E6; padding: 5px; margin: 5px auto; width: 150px;">AUXILIARY MENU</div>			
<div style="background-color: #ADD8E6; padding: 5px; margin: 5px auto; width: 150px;">OPEN DOOR</div>					
CHAMBER PRESSURE	0959mb	BOILER PRESSURE	4.5bar	JACKET TEMPERATURE	135.3°C
JACKET PRESSURE	3160mb			LAST CYCLE NUMBER	000101
DOOR 1 LOADING SIDE		DATE	Wednesday 09/05/2018	TIME	10:26:28

Select the required cycle by pressing the appropriate key.

STARTING A CYCLE

If the cycle requires an I.D. and passcode in order to start, the following screen will be displayed.

Authorising start of cycle					
ID	<input type="text"/>				
PASSCODE	<input type="text"/>				
<input type="button" value="EXIT"/>					
CHAMBER PRESSURE	0959mb	BOILER PRESSURE	4.5bar	JACKET TEMPERATURE	135.3°C
JACKET PRESSURE	3160mb			LAST CYCLE NUMBER	000101
DOOR 1 LOADING SIDE			DATE	Wednesday 09/05/2018	TIME 10:26:28

Pressing exit will return to the cycle selection menu

On entering a valid I.D. and passcode combination, the seal door screen will be displayed as below.

Cycle Start – Seal Door					
CYCLE X					
<input type="button" value="SEAL DOOR 1"/>			<input type="button" value="EXIT"/>		
CHAMBER PRESSURE	0959mb	BOILER PRESSURE	4.5bar	JACKET TEMPERATURE	135.3°C
JACKET PRESSURE	3160mb			LAST CYCLE NUMBER	000101
DOOR 1 LOADING SIDE			DATE	Wednesday 09/05/2018	TIME 10:26:28

Pressing exit will return to the cycle selection menu

Cycle Start – Select Cycle Start Option					
CYCLE X					
<input type="button" value="START CYCLE"/>			<input type="button" value="EXIT"/>		
CHAMBER PRESSURE	0959mb	BOILER PRESSURE	4.5bar	JACKET TEMPERATURE	135.3°C
JACKET PRESSURE	3160mb			LAST CYCLE NUMBER	000101
DOOR 1 LOADING SIDE			DATE	Wednesday 09/05/2018	TIME 10:26:28

Pressing exit will return to the cycle selection menu

Cycle Start

STARTING A CYCLE

Starting a Test Cycle

If the selected cycle is a test cycle and therefore unsuitable for processing loads, the screen will be displayed as below:

Main Menu – Door Closed					
					NOT STERILE
CYCLE X					
THIS CYCLE IS NOT SUITABLE FOR PROCESSING LOADS					
CONTINUE ANYWAY			EXIT		
CHAMBER PRESSURE	0959mb	BOILER PRESSURE	4.5bar	JACKET TEMPERATURE	135.3°C
JACKET PRESSURE	3160mb			LAST CYCLE NUMBER	000101
DOOR 1 LOADING SIDE		DATE	Wednesday 09/05/2018	TIME	10:26:28

If the cycle requires an I.D. and passcode in order to start, the following screen will be displayed.

Authorising start of cycle					
ID	<input type="text"/>				
PASSCODE	<input type="text"/>				
EXIT					
CHAMBER PRESSURE	0959mb	BOILER PRESSURE	4.5bar	JACKET TEMPERATURE	135.3°C
JACKET PRESSURE	3160mb			LAST CYCLE NUMBER	000101
DOOR 1 LOADING SIDE		DATE	Wednesday 09/05/2018	TIME	10:26:28

On entering a valid I.D. and passcode combination, the seal door screen will be displayed as below.

Cycle Start – Seal Door					
CYCLE X					
SEAL DOOR 1			EXIT		
CHAMBER PRESSURE	0959mb	BOILER PRESSURE	4.5bar	JACKET TEMPERATURE	135.3°C
JACKET PRESSURE	3160mb			LAST CYCLE NUMBER	000101
DOOR 1 LOADING SIDE		DATE	Wednesday 09/05/2018	TIME	10:26:28

STARTING A CYCLE

Once the door is sealed the cycle start screen will be displayed. If the cycle is configured so that a start time can be entered the set time to start cycle key will be displayed.

Cycle Start – Select Cycle Start Option					
CYCLE X					
START CYCLE			EXIT		
CHAMBER PRESSURE	0959mb	BOILER PRESSURE	4.5bar	JACKET TEMPERATURE	135.3°C
JACKET PRESSURE	3160mb			LAST CYCLE NUMBER	000101
DOOR 1 LOADING SIDE		DATE	Wednesday 09/05/2018	TIME	10:26:28

Cycle Start

Starting a Time-Set Cycle

If the selected cycle has the time-set option enabled, the cycle start screen will be displayed as below:

Cycle Start – Select Cycle Start Option					
CYCLE X					
START CYCLE			SET TIME TO START CYCLE		
START CYCLE			EXIT		
CHAMBER PRESSURE	0959mb	BOILER PRESSURE	4.5bar	JACKET TEMPERATURE	135.3°C
JACKET PRESSURE	3160mb			LAST CYCLE NUMBER	000101
DOOR 1 LOADING SIDE		DATE	Wednesday 09/05/2018	TIME	10:26:28

On pressing the set time to start cycle key, the user will be prompted to enter a start date and time.

Time Set Cycle Start – Check/Set Date For Timed Start					
CYCLE X					
START DATE		10	/	05	/ 2018
START TIME		10	/	30	
START CYCLE			EXIT		
CHAMBER PRESSURE	0959mb	BOILER PRESSURE	4.5bar	JACKET TEMPERATURE	135.3°C
JACKET PRESSURE	3160mb			LAST CYCLE NUMBER	000101
DOOR 1 LOADING SIDE		DATE	Wednesday 09/05/2018	TIME	10:26:28

STARTING A CYCLE

On entering a valid start time the option to enter standby mode becomes available.

Time Set Cycle Start – Check/Set Date For Timed Start					
CYCLE X					
TIME SET CYCLE START SET : Thursday 10/05/2018 10:30					
START DATE		10	/	05	/ 2018
START TIME		10	/	30	
STANDBY MODE					
START CYCLE				EXIT	
CHAMBER PRESSURE	0959mb	BOILER PRESSURE	4.5bar	JACKET TEMPERATURE	135.3°C
JACKET PRESSURE	3160mb			LAST CYCLE NUMBER	000101
DOOR 1 LOADING SIDE			DATE	Wednesday 09/05/2018	TIME 10:26:28

On pressing standby mode the screen will turn blank, it can be reactivated at any point by touching it.

When the time set cycle is about to begin the following screen will be displayed.

Cycle Start – Select Cycle Start Option					
!! WARNING – TIME SET CYCLE ABOUT TO START !!					
CHAMBER PRESSURE	0959mb	BOILER PRESSURE	4.5bar	JACKET TEMPERATURE	135.3°C
JACKET PRESSURE	3160mb			LAST CYCLE NUMBER	000101
DOOR 1 LOADING SIDE			DATE	Wednesday 09/05/2018	TIME 10:26:28

Cycle Start

Ending a Cycle

At the end of the cycle the screen will appear as below. The cycle name and whether the cycle was a pass or a fail will be displayed. If the cycle has failed the message 'NON-STERILE LOAD IN CHAMBER' will be displayed:

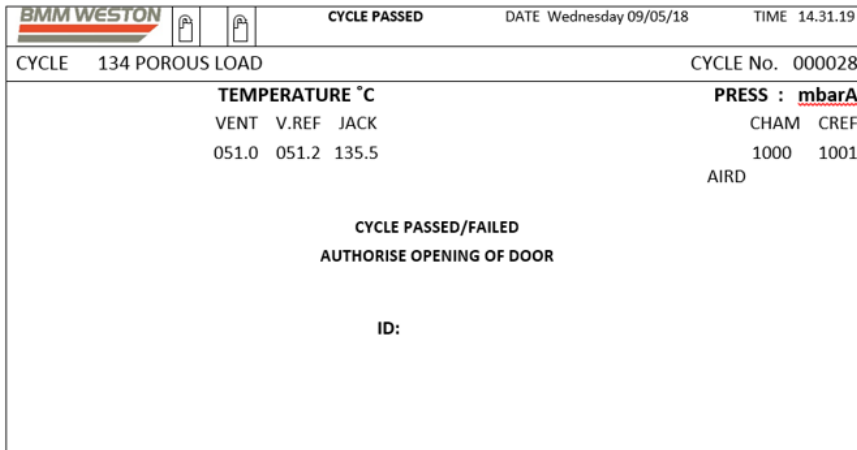

The prompt for an I.D. will only appear if the cycle has been configured to require an I.D. and passcode to end.

On entering a valid I.D. and passcode combination the option to unseal the door will be available.

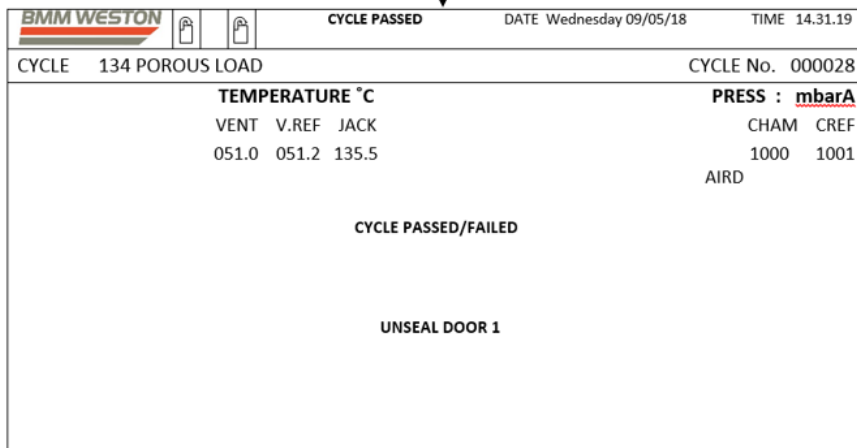

Read the safety instructions section at the front of this manual for the safe operation of the door following a cycle.

Once the door is unsealed the option to open the door will be available.

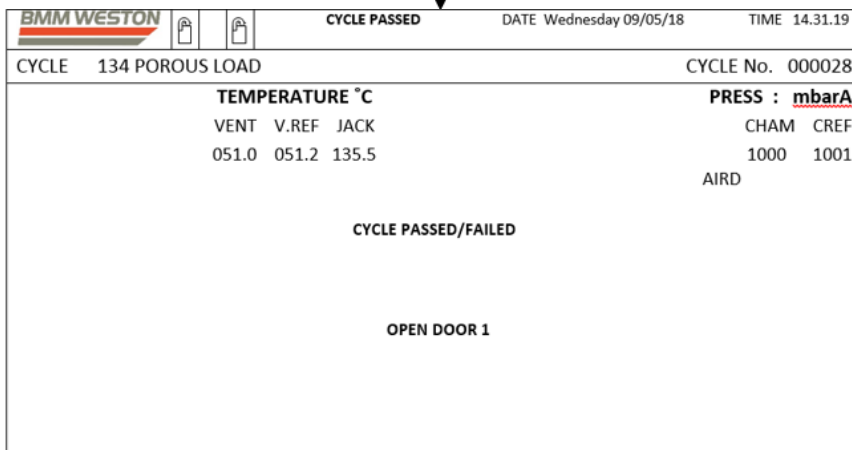

Transfer the load out of the sterilizer, making sure that no part of the load touches the chamber walls. Read the safety instructions section at the front of this manual for the safe handling of loads in and out of the sterilizers.

Cycle End

Auxiliary Menus:

The Auxiliary Menu screen can be accessed from the main menu whether the door is open or closed. The screen will be displayed as below:

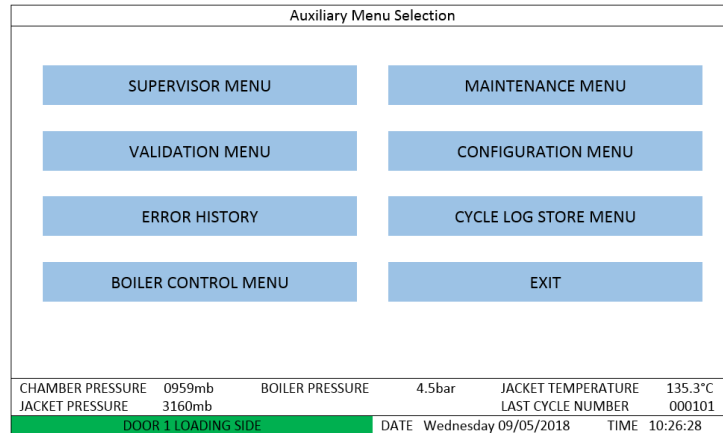

1. SUPERVISOR MENU

Set of menus for configuring the data input requirements for starting and ending a cycle. Also general tools for handling data storage facilities.

2. MAINTENANCE MENU

Set of menus to assist the maintenance engineer. These include door operations, input and output status of microprocessor control signals, calibration of analogue signals, and video and printer checks.

3. VALIDATION MENU

A set of menus used to configure the process cycles variables. These would include variables to control the steam/vacuum pulsing during the air removal stage, sterilizing temperature limits and times, and drying vacuum levels and times.

4. CONFIGURATION MENU

Set of menus used to configure the basic set-up characteristics for the sterilizer. These include the specifying of the number of doors, number and type of analogue channels and the number of cycles the sterilizer will support.

5. ERROR HISTORY

Menu displaying the date, time and details of any errors that have occurred both in and out of cycle.

6. CYCLE LOG STORE MENU

Set of menus for viewing cycle logs that have been store in the sterilizer control system memory. Also details how cycle logs can be reprinted and general management features on log storage.

7. BOILER CONTROL MENU

Menu that describes the status of the integral boiler (if fitted) and allows for the boiler to be started or stopped.

SUPERVISOR MENU – CYCLE DEPENDENT OPTIONS

Supervisor Menu – Cycle Dependent Options:

The Supervisor Menu can be accessed by pressing the Supervisor Menu key from the Auxiliary Menus screen and inputting a valid I.D. and passcode combination at supervisor level or above. The screen will appear as below:

Supervisor Menu

CYCLE DEPENDENT OPTIONS GENERAL OPTIONS

EXIT

CHAMBER PRESSURE 0959mb BOILER PRESSURE 4.5bar JACKET TEMPERATURE 135.3°C
 JACKET PRESSURE 3160mb LAST CYCLE NUMBER 000101
 DOOR 1 LOADING SIDE DATE Wednesday 09/05/2018 TIME 10:26:28

Press the Exit key to return to the Supervisor Menu

Press the Cycle Dependent Options key

Supervisor Menu - Cycle Dependent Options

CYCLE 1 CYCLE 2
 CYCLE 3 CYCLE 4
 CYCLE 5 CYCLE 6
 CYCLE 7 EXIT

CHAMBER PRESSURE 0959mb BOILER PRESSURE 4.5bar JACKET TEMPERATURE 135.3°C
 JACKET PRESSURE 3160mb LAST CYCLE NUMBER 000101
 DOOR 1 LOADING SIDE DATE Wednesday 09/05/2018 TIME 10:26:28

Press the Exit Key

Select a cycle

If sub-cycles are available the sub-cycle selection menu will be displayed on selecting a cycle:

Supervisor Menu - Cycle Dependent Options

CYCLE X-1 CYCLE X-2
 CYCLE X-3 CYCLE X-4
 CYCLE X-5 CYCLE X-6
 CYCLE X-7 EXIT

CHAMBER PRESSURE 0959mb BOILER PRESSURE 4.5bar JACKET TEMPERATURE 135.3°C
 JACKET PRESSURE 3160mb LAST CYCLE NUMBER 000101
 DOOR 1 LOADING SIDE DATE Wednesday 09/05/2018 TIME 10:26:28

CYCLE X-X

ID REQUIRED TO START CYCLE Yes ▾

LEVEL OF ID REQUIRED TO START CYCLE 1 2 3 4

ID REQUIRED TO END PASS CYCLE Yes ▾

LEVEL OF ID REQUIRED TO END PASS CYCLE 1 2 3 4

ID REQUIRED TO END FAILED CYCLE Yes ▾

LEVEL OF ID REQUIRED TO END FAILED CYCLE 0 0 3 4

TIME SET CYCLE OPTION Yes ▾ MINI/DETAIL LOG Mini ▾

PRINT SAVE PROFILE TO .STX TEXT FILE EXIT

CHAMBER PRESSURE 0959mb BOILER PRESSURE 4.5bar JACKET TEMPERATURE 135.3°C
 JACKET PRESSURE 3160mb LAST CYCLE NUMBER 000101
 DOOR 1 LOADING SIDE DATE Wednesday 09/05/2018 TIME 10:26:28

ITEM	DESCRIPTION
ID REQUIRED TO START CYCLE	Dropdown box selection with Yes or No determining whether or not an ID and passcode are required to start the cycle in question.
LEVEL OF ID REQUIRED TO START CYCLE	Each field corresponds to ID level 1-4. Input the corresponding digit for the ID level to be able to start the cycle or input a 0 if the ID level is unable to start the cycle.
ID REQUIRED TO END PASS CYCLE	Dropdown box selection with Yes or No determining whether an ID and passcode are required to end the cycle in question when it passes.
LEVEL OF ID REQUIRED TO END PASS CYCLE	Each field corresponds to ID level 1-4. Input the corresponding digit for the ID level to be able to end the passing cycle or input a 0 if the ID level is unable to end the passing cycle.
ID REQUIRED TO END FAILED CYCLE	Dropdown box selection with Yes or No determining whether an ID and passcode are required to end the cycle in question when it fails.
LEVEL OF ID REQUIRED TO END FAILED CYCLE	Each field corresponds to ID level 1-4. Input the corresponding digit for the ID level to be able to end the failing cycle or input a 0 if the ID level is unable to end the failing cycle.
TIME SET CYCLE OPTION	Dropdown box selection with Yes or No determining whether or not the option to set a start time for the cycle in question is available.
MINI/DETAIL LOG	Dropdown box selection with Mini or Detail determining the level of detail expressed in the data log.

Press the Exit key once desired changes have been made to save them. Press the Print key to print the Supervisor profile for the cycle or press the Save Profile key to save them to a text file.

CYCLE LOG STORE MENU

Supervisor Menus – Copying Profiles From Cycle to Cycle:

The Supervisor Menu can be accessed by pressing the Supervisor Menu key from the Auxiliary Menus screen and inputting a valid I.D. and passcode combination at supervisor level or above. The screen will appear as below:

Supervisor Menu

CYCLE DEPENDENT OPTIONS

GENERAL OPTIONS

EXIT

CHAMBER PRESSURE	0959mb	BOILER PRESSURE	4.5bar	JACKET TEMPERATURE	135.3°C
JACKET PRESSURE	3160mb			LAST CYCLE NUMBER	000101
DOOR 1 LOADING SIDE		DATE	Wednesday 09/05/2018	TIME	10:26:28

Press the Exit key to return to the Supervisor Menu

Press the General Options key

Supervisor Menu - General Options

COPY PROFILE CYCLE TO CYCLE

MENU ENTRY LOGS

CHANGE ID'S & PASSCODES

VISUAL CHART RECORDING MODE

1. ENABLE VISUAL CHART RECORDING

↓

EXIT

CHAMBER PRESSURE	0959mb	BOILER PRESSURE	4.5bar	JACKET TEMPERATURE	135.3°C
JACKET PRESSURE	3160mb			LAST CYCLE NUMBER	000101
DOOR 1 LOADING SIDE		DATE	Wednesday 09/05/2018	TIME	10:26:28

The Visual Chart Recording Mode dropdown box allows the user to enable or disable visual chart recording during the cycle by selecting the corresponding option.

Copy Supervisor Profiles Cycle to Cycle

SELECT SOURCE PROFILE (COPY FROM)

X

X

-

X

SELECT TARGET PROFILE (COPY TO)

X

X

-

X

COPY

EXIT

CHAMBER PRESSURE	0959mb	BOILER PRESSURE	4.5bar	JACKET TEMPERATURE	135.3°C
JACKET PRESSURE	3160mb			LAST CYCLE NUMBER	000101
DOOR 1 LOADING SIDE		DATE	Wednesday 09/05/2018	TIME	10:26:28

The Copy Supervisor Profile menu allows a Supervisor Profile to be copied from one cycle to another.

On pressing the Select Source Profile data entry field a keypad will appear and allow the number of the source profile to be entered in the format (x-x).

On pressing the Select Target Profile data entry field a keypad will appear and allow the number of the target profile to be entered in the format (x-x).

On pressing copy the supervisor profile data values of the source profile will be copied over to the target profile.

Press the Exit key to return to the General Options Menu.

CYCLE LOG STORE MENU

Supervisor Menu - Menu Entry Logs:

The Supervisor Menu can be accessed by pressing the Supervisor Menu key from the Auxiliary Menus screen and inputting a valid I.D. and passcode combination at supervisor level or above. The screen will appear as below:

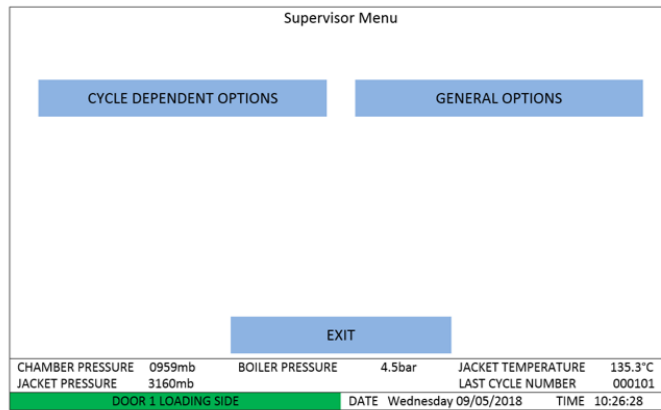

Press the Exit key to return to the Supervisor Menu
 Press the General Options key

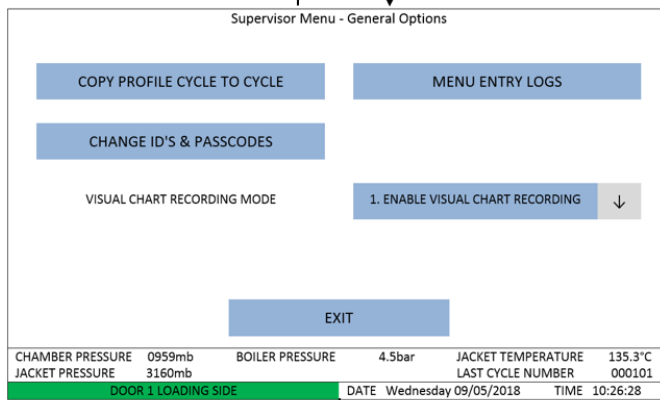

Press the Menu Entry Logs Key

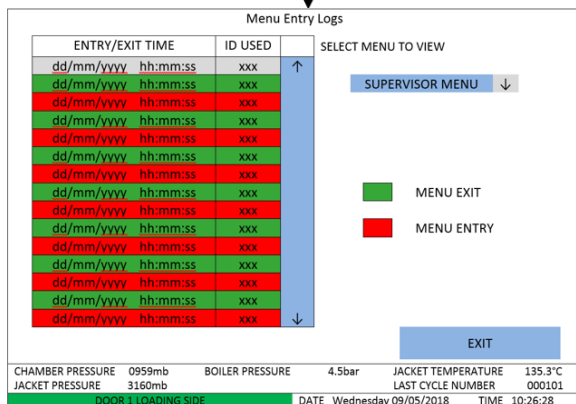

The screen displays a dated and time list of all supervisor menu entries and exits and their corresponding I.D.s.

Entries are coloured in green whilst exits are coloured in red.

The dropdown menu allows the corresponding information to be viewed for the Validation, Maintenance and Configuration menus.

Press the Exit key to return to the General Options Menu.

CYCLE LOG STORE MENU

Supervisor Menu - Change I.D.s and Passcodes:

The Supervisor Menu can be accessed by pressing the Supervisor Menu key from the Auxiliary Menus screen and inputting a valid I.D. and passcode combination at supervisor level or above. The screen will appear as below:

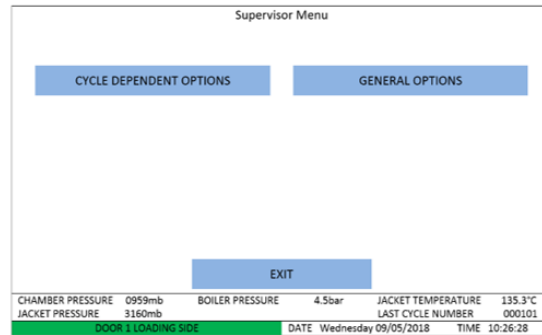

Press the Exit key to return to the Supervisor Menu ↑ Press the General Options key ↓

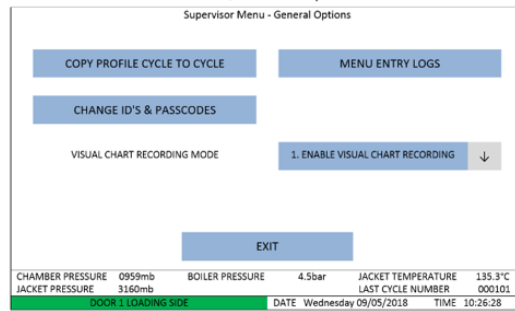

Press the Exit Key to return to the General Options Menu ↑ Press the Change I.D.s & Passcodes Key ↓

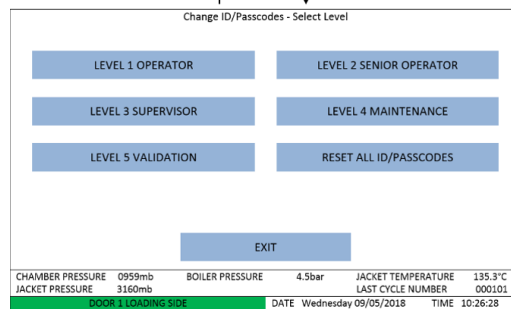

This screen displays keys corresponding to each level of access. Levels of access exceeding that of the I.D. and Passcode used to access the supervisor menu will be inaccessible.

Pressing a key will allow I.D.s and Passcodes at that level of access to be changed.



The screen displays a list of all I.D.s and Passcodes at the selected access level. By pressing an I.D. or Passcode data entry field a keypad will appear and enable the user to change that I.D. or Passcode.

Pressing the Reset Level I.D./Passcodes key will present the user with a warning and ask them to confirm their decision. Upon doing so all of the I.D.s and Passcodes at this level of access will be reset to their default values.

Press the Exit key to return to the General Options Menu.

CYCLE LOG STORE MENU

The Cycle Log Store Menu can be accessed by pressing the Cycle Log Store Menu key from the Auxiliary Menus screen and inputting a valid I.D. and passcode combination. The screen will appear as below:

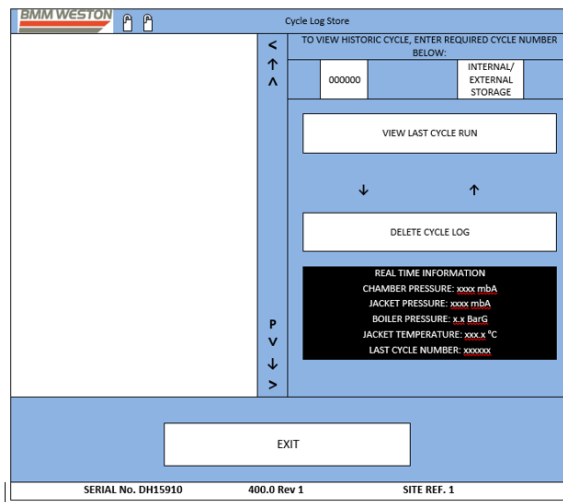

Press the Internal/External Storage key to switch between accessing files stored on the system's internal memory or on files stored on a USB drive. Key will display Internal Storage symbol or External Storage symbol as appropriate.

Press the Exit key to return to the Auxiliary Menus screen.

Press the View Last Cycle Run or enter the desired cycle number to view the data log for that cycle.

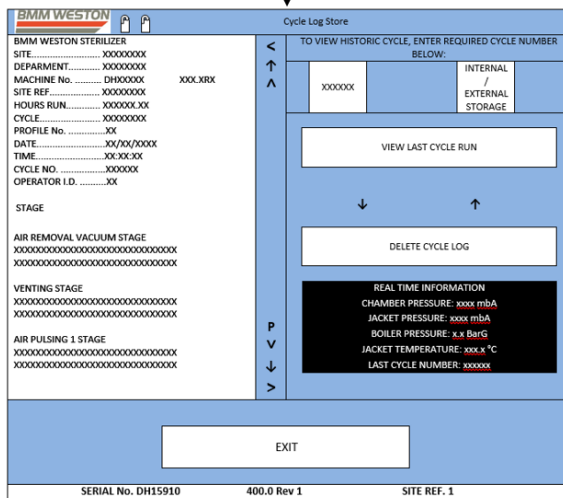

Use the arrow keys to navigate the cycle log. The small arrows keys will move the data log by one line in the appropriate direction, the large Up and Down arrow keys will navigate to the top or bottom of the display respectively.

Pressing the Delete Cycle Log key will prompt the user to confirm their decision. On doing so the selected cycle log will be deleted.

Press the Exit key to return to the Auxiliary menu screen.

Once the printing operation has been cancelled or has completed the Cycle Log Store Menu will be displayed.

Press the P key to print the selected cycle log.

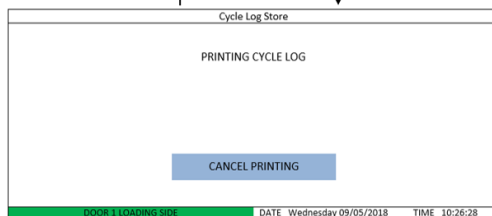

BOILER CONTROL MENU

Integral Boiler Control

The Boiler Control Menu can be accessed by pressing the Boiler Control Menu key from the Auxiliary Menus screen. When the boiler is not running, the screen will appear as below:

Boiler Control Menu			
	CURRENT STATUS	AT LAST LOCKOUT	
BOILER IS RUNNING	NO	NO	NO
WATER IS AVAILABLE TO FEED BOILER	YES	YES	YES
WATER IS WITHIN THE CONTROLLED HIGH LEVEL BAND	NO	NO	NO
WATER LEVEL IS ABOVE THE MINIMUM LOW LEVEL	NO	NO	NO
WATER PUMP OVERLOAD HAS TRIPPED	YES	YES	YES
BOILER IS IN LOCKOUT MODE	YES	YES	YES
BOILER OVER PRESSURE DETECTED – PRESSURE SWITCH	NO	NO	NO
BOILER OVER PRESSURE DETECTED - TRANSDUCER	NO	NO	NO
BOILER LOW WATER LEVEL DETECTED	NO	NO	NO
BOILER OVER TEMPERATURE DETECTED	NO	NO	NO
BOILER MCB SHUNT TRIP HAS BEEN OPERATED	YES	YES	YES
BOILER MCB HAS TRIPPED (BANK 1, 2, 3)	NO NO NO	NO NO NO	NO NO NO
OVERFILL/WATER LEVEL SENSOR ERROR	NO	NO	NO
EMERGENCY SWITCH HAS BEEN OPERATED	NO	NO	NO
AIR SERVICE FAILED	NO	NO	NO
FILLING WATCHDOG TIMEOUT	NO	NO	NO
HEATING WATCHDOG TIMEOUT	NO	NO	NO
HEATER CONTACTOR FAILED CLOSED (BANK 1, 2, 3)	NO NO NO	NO NO NO	NO NO NO
HEATER CONTACTOR FAILED OPEN (BANK 1, 2, 3)	NO NO NO	NO NO NO	NO NO NO
START BOILER		EXIT	
CHAMBER PRESSURE	0959mb	BOILER PRESSURE	4.5bar
JACKET PRESSURE	3160mb	JACKET TEMPERATURE	135.3°C
		LAST CYCLE NUMBER	000101
DOOR 1 LOADING SIDE		DATE	Wednesday 09/05/2018
		TIME	10:26:28

The screen displays boiler information that can be used for fault diagnosis in the event of a boiler lockout.

Press the Start Boiler key

Boiler Control Menu			
	CURRENT STATUS	AT LAST LOCKOUT	
BOILER IS RUNNING	YES	NO	NO
WATER IS AVAILABLE TO FEED BOILER	YES	YES	YES
WATER IS WITHIN THE CONTROLLED HIGH LEVEL BAND	YES	NO	NO
WATER LEVEL IS ABOVE THE MINIMUM LOW LEVEL	YES	NO	NO
WATER PUMP OVERLOAD HAS TRIPPED	NO	YES	YES
BOILER IS IN LOCKOUT MODE	NO	YES	YES
BOILER OVER PRESSURE DETECTED – PRESSURE SWITCH	NO	NO	NO
BOILER OVER PRESSURE DETECTED - TRANSDUCER	NO	NO	NO
BOILER LOW WATER LEVEL DETECTED	NO	NO	NO
BOILER OVER TEMPERATURE DETECTED	NO	NO	NO
BOILER MCB SHUNT TRIP HAS BEEN OPERATED	NO	YES	YES
BOILER MCB HAS TRIPPED (BANK 1, 2, 3)	NO NO NO	NO NO NO	NO NO NO
OVERFILL/WATER LEVEL SENSOR ERROR	NO	NO	NO
EMERGENCY SWITCH HAS BEEN OPERATED	NO	NO	NO
AIR SERVICE FAILED	NO	NO	NO
FILLING WATCHDOG TIMEOUT	NO	NO	NO
HEATING WATCHDOG TIMEOUT	NO	NO	NO
HEATER CONTACTOR FAILED CLOSED (BANK 1, 2, 3)	NO NO NO	NO NO NO	NO NO NO
HEATER CONTACTOR FAILED OPEN (BANK 1, 2, 3)	NO NO NO	NO NO NO	NO NO NO
STOP BOILER		EXIT	
CHAMBER PRESSURE	0959mb	BOILER PRESSURE	4.5bar
JACKET PRESSURE	3160mb	JACKET TEMPERATURE	135.3°C
		LAST CYCLE NUMBER	000101
DOOR 1 LOADING SIDE		DATE	Wednesday 09/05/2018
		TIME	10:26:28

Press the Exit key to return to the Auxiliary Menus screen.

Printer

The printer is situated on the front control panel. The printer provides a record of process variables and times throughout the sterilizing cycle – the cycle log. In addition to the cycle log, the contents of the Supervisor, Validation and Configuration menus can be printed for archiving purposes.

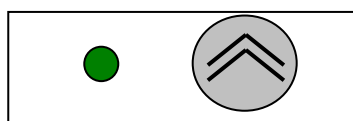

Status LED Mode Button

STATUS LED

The printer incorporates an LED indicator to report its condition. If there is a fault, the LED will flash in sequence. The fault can be identified by counting the number of flashes.

LED INDICATION	CONDITION	SOLUTION
●	Printer On	-
●	Printer Off	-
● ● ●	Paper out or door open	Fit new paper
● ● ● ● ● ● ● ●	Thermal head too hot	Allow head to cool

Depressing the mode button will allow paper to be fed through the printer. When removing printout from the printer, pull the printout toward the tear bar and tear from one side to the other across the serrated edge.

HEAD THERMAL LIMIT

After extensive printing the print head temperature may rise to an unusable level. The status LED will report when this occurs, and printing will be suspended until the head temperature returns to normal levels.

PRINTER SELF-CHECK

A printer self-check can be performed to check the print quality of the printer.

- a) Turn the printer off.
- b) Push in and hold the mode button. Whilst still held in, push the on/off button to turn the printer on again.
- c) When the mode button is released, paper will start to be fed from the printer and characters to be printed. After 5 seconds release the paper feed button. The printer will continue to print until the self check is complete. Examine the characters for print quality and for correct operation of the print mechanism.

REPLACING THE PRINTER PAPER

- a) The printer will automatically detect when the printer paper has run out, and report this using the Status LED. Use the Mode button to feed through the last centimeters of paper and fit a new roll.
- b) Pull the lever until the lid is released from its locked position. To avoid damage do not use excessive force.
- c) If the paper roll needs replacing, open the paper cup lid and remove the remaining paper. Reel off a few centimeters from a new roll of paper. Hold approximately 5cm of paper outside the device as you place the new roll into the reservoir. Close the lid by applying equal amount of pressure on each side ensuring the lid is in the locked position. Now tear the spare paper away.

SERVICE REQUIREMENTS

Spare Parts

The following spare parts are available from BMM Weston;

Description	Part Number	Qty
Printer "thermal" Paper	H15746	10
Door Seal (Series 1)	H23270/H24398*	2
Door Seal (Series 2)	H12192/H21590*	2
Door Seal (Series 3)	H21441/H23776*	2
PTFE Silicon Grease	C7080	1 can
Air Filter	60101	2
O Ring - 6mm	190623	10
O Ring - 15mm	190625	10
Tri-Clamp Seal - 1"	H9189	10
PTFE Tri-Clamp Seal - 1.1/2"	H9190	10
Seal Kit for steam inlet valves	DS586	2
Actuator Kit for steam inlet valve	DS 575	2
Seal Kit for Vacuum Valve	DS 589	1
Actuator Kits Vacuum Valve	DS 576	1
Seal Kit - 3/8" SMC Valve	DS 767	2
Spares Kit for Jacket steam Trap	DS 510	2
Push fit pneumatic elbow (1/4"BSP x 4mm)	C4598	5
Fuse 1A	H10010	2
Fuse 2A	H10011	2
Fuse 3.15A	H10388	2
Fuse 5A	H10012	2

*Contact BMM Weston Ltd. to determine appropriate door seal for your machine.

SERVICE REQUIREMENTS

FOR SPARE PARTS CONTACT BMM SERVICE DIVISION:

BMM Service Helpdesk on 01795 597127
or Main Switchboard on 01795 533441 then key 1 for Service Helpdesk
BMM Service Fax No. 01795 538891
BMM Service E-mail service@bmmweston.co.uk
BMM Weston Website www.bmmweston.com

Before contacting BMM Weston it would be useful to know

Machine Type

Serial No.

Model No.

THIS MANUAL WAS PRINTED AND PUBLISHED IN ENGLAND BY:-

BMM WESTON LTD, WESTON WORKS, FAVERSHAM, KENT, ENGLAND

Head Office: Phone 01795 533441 Fax 01795 538891 Email: mail@bmmweston.com Website: www.bmmweston.com

Service Dept: Phone 01795 597127 Fax 01795 538891 Email: service@bmmweston.co.uk

BMM WESTON

Sterilizers